



STATE OF CALIFORNIA, COUNTY OF SIERRA
BOARD OF SUPERVISORS
AGENDA
SPECIAL TELECONFERENCE MEETING

Lee Adams, District 1

P.O. Box 1 - Downieville, CA 95936 - 530-289-3506 - supervisor1@sierracounty.ca.gov

Peter W. Huebner, District 2

P.O. Box 349 - Sierra City, CA 96125 - 530-565-6055 - phuebner@sierracounty.ca.gov

Paul Roen, Chair, District 3

P.O. Box 43 - Calpine, CA 96124 - 530-565-6048 - supervisor3@sierracounty.ca.gov

Jim Beard, Vice-Chair, District 4

P.O. Box 1140 - Loyalton, CA 96118 - 530-565-6092 - jbeard@sierracounty.ca.gov

Sharon Dryden, District 5

P.O. Box 246 - Loyalton, CA 96118 - 530-913-9218 - sdryden@sierracounty.ca.gov

The Sierra County Board of Supervisors will meet in special session commencing at 12:00 p.m. on March 21, 2019. Locations available to the public to attend the teleconference meeting will be in the Board of Supervisors' Chambers, Courthouse, Downieville, CA and the Sierra County Probation Department, 105 Beckwith Street, Loyalton, CA. This meeting will be recorded for posting on the Board of Supervisors' website at www.sierracounty.ca.gov.

NOTICE

If requested, this agenda can be made available in appropriate alternative formats to persons with a disability, as required by Section 202 of the Americans with Disabilities Act of 1990 and the Federal Rules and Regulations adopted in implementation thereof. Persons seeking an alternative format should contact the Clerk of the Board for further information. In addition, a person with a disability who requires a modification or accommodation, in order to participate in a public meeting should telephone or otherwise contact the Clerk of the Board as soon as possible and at least 48 hours prior to the meeting. The Clerk of the Board may be reached at 530-289-3295 or at the following addresses:

Heather Foster
Clerk of the Board of Supervisors
County of Sierra
100 Courthouse Square, Room 11
P.O. Drawer D
Downieville, CA 95936
clerk-recorder@sierracounty.ca.gov

All items posted on the agenda, including under correspondence, may be acted upon by the Board of Supervisors. However, matters under committee reports and department manager's reports may be briefly addressed by the Board or Staff but no action or discussion shall be undertaken on any item not appearing on the posted agenda. (GC 54954.2)

The Board of Supervisors may hold a Closed Session as the agenda schedule permits.

REGULAR AGENDA

1. STANDING ORDERS

- Call to Order
- Pledge of Allegiance
- Roll Call
- Approval of Regular Agenda

2. PUBLIC COMMENT OPPORTUNITY

Matters under the jurisdiction of the Board not on this posted agenda may be addressed by the general public during the Public Comment Opportunity time. No action may be taken or substantive discussion pursued on matters not on the posted agenda. Public comment is regulated by the Sierra County Board of Supervisors' Rules and Procedures. You may obtain a copy of the Public Comment rules from the Clerk. The Board limits public comment to three minutes per person and not more than three individuals addressing the same subject.

3. PUBLIC WORKS/TRANSPORTATION - TIM BEALS

- 3.A. Resolution abandoning a portion of an offer of dedication that was offered in perpetuity to the County as part of the approval of the Sierra Valley Senior Community located on Hill Street adjacent to the City of Loyalton.

Documents:

[Hill Street Abandon ROP.pdf](#)

4. CLOSED SESSION

- 4.A. Closed session pursuant to Government Code section 54956.9(a) - conference with legal counsel regarding the following litigation: Sierra County v. Loyalton Mobile Home Park, Sierra County Superior Court Case No. 7677.

Documents:

[Closed Session Loyalton Mobile Home Park.pdf](#)

ADJOURN

**Sierra County
Board of Supervisors'
Agenda Transmittal &
Record of Proceedings**

MEETING DATE: March 2 , 2019	TYPE OF AGENDA ITEM: <input checked="" type="checkbox"/> Regular <input type="checkbox"/> Timed <input type="checkbox"/> Consent
DEPARTMENT: Department of Public Works and Transportation APPROVING PARTY: Tim H. Beals, Director PHONE NUMBER: 530-289-3201	

AGENDA ITEM: Adoption of Resolution abandoning a portion of an offer of dedication that was offered in perpetuity to the County as part of the approval of the Sierra Valley Senior Community located on Hill Street adjacent to the City of Loyalton.

SUPPORTIVE DOCUMENTS ATTACHED: Memo Resolution Agreement Other

BACKGROUND INFORMATION: A Resolution of Intent was adopted on February 5, 2019 and a public hearing was opened on March 5, 2019 and is continued to March 19, 2019. An updated description of the proposed vacation is being provided based on the outcome of the March 19, 2019 meeting and a special meeting is scheduled to complete this process.

FUNDING SOURCE:
GENERAL FUND IMPACT: No General Fund Impact
OTHER FUND:
AMOUNT: \$ N/A

ARE ADDITIONAL PERSONNEL REQUIRED? <input type="checkbox"/> Yes, -- -- <input type="checkbox"/> No	IS THIS ITEM ALLOCATED IN THE BUDGET? <input type="checkbox"/> Yes <input type="checkbox"/> No IS A BUDGET TRANSFER REQUIRED? <input type="checkbox"/> Yes <input type="checkbox"/> No
---	---

SPACE BELOW FOR CLERK'S USE

BOARD ACTION: <input type="checkbox"/> Approved <input type="checkbox"/> Approved as amended <input type="checkbox"/> Adopted <input type="checkbox"/> Adopted as amended <input type="checkbox"/> Denied <input type="checkbox"/> Other <input type="checkbox"/> No Action Taken	<input type="checkbox"/> Set public hearing For: _____ <input type="checkbox"/> Direction to: _____ <input type="checkbox"/> Referred to: _____ <input type="checkbox"/> Continued to: _____ <input type="checkbox"/> Authorization given to: _____	Resolution 2019- _____ Agreement 2019- _____ Ordinance _____ Vote: Ayes: Noes: Abstain: Absent: <input type="checkbox"/> By Consensus
---	---	---

COMMENTS:

CLERK TO THE BOARD

DATE

WHEN RECORDED MAIL DOCUMENT TO:

**Tim H. Beals
Sierra County
Director of Transportation
Post Office Box 98
Downieville, CA 95936**

STATE OF CALIFORNIA, COUNTY OF SIERRA, BOARD OF SUPERVISORS

**IN THE MATTER OF VACATION OF A
PORTION OF A STREET, HIGHWAY OR PUBLIC EASEMENT
AFFECTING AN OFFER OF DEDICATION ON HILL STREET
ADJACENT TO THE CITY OF LOYALTON**

RESOLUTION NO. 2019-_____

WHEREAS, on February 5, 2019 the Sierra County Board of Supervisors adopted Resolution 2019-021 setting a date for a public hearing and declaring intent to vacate a portion of an irrevocable offer of dedication as shown on Book 5, MS Page 76, affecting a portion of lot 1 of the Parcel Map for a Subdivision in Two parts for Gwendolyn Lynch, March 1978, the parcel of land whereupon the Sierra Senior Apartments are located; and,

WHEREAS, Notice of Public Hearing for March 5, 2019 was duly published and posted as required by law.

NOW, THEREFORE, BE IT RESOLVED that the Board of Supervisors of the County of Sierra find as follows:

- A) The Sierra County Board of Supervisors duly published public hearing notices, posted public hearing notices on or near the property and in public places and reviewed public testimony and staff reports as part of the record of proceedings for a public hearing conducted on March 5, 2019 and continued to March 19, 2019 at which time the public hearing was closed.
- B) The Board determined that a vacation of a portion of the offer of dedication as shown on the map attached hereto as Exhibit A and the legal description of the proposed vacation as described in Exhibit B would be in the public interest and therefore approves and orders such vacation.
- C) Based upon the record, the proposed vacation shall be exempt from the California Environmental Quality Act, and the Planning Director is directed to file the appropriate exemption form with the County Recorder upon recordation of this resolution.

D) The Clerk of the Board is directed to record this resolution consistent with the law.

Adopted by the Board of Supervisors of the County of Sierra, State of California on the 21st day of March, 2019 by the following vote:

AYES:

NOES:

ABSTAIN:

ABSENT:

COUNTY OF SIERRA

PAUL ROEN
CHAIRMAN, BOARD OF SUPERVISORS

ATTEST:

APPROVED AS TO FORM:

HEATHER FOSTER
CLERK OF THE BOARD

DAVID PRENTICE
COUNTY COUNSEL

510.000
N89° 58' 27.00"W

33' COUNTY OF SIERRA
CENTER SECTION 13

HILL ST.



PORTION 1
SEE DETAIL 'B' FOR
ENLARGED VIEW

PORTION 2
SEE DETAIL 'A' FOR
ENLARGED VIEW

S00° 03' 00.00"E
854.250

N00° 03' 00.00"W
854.250

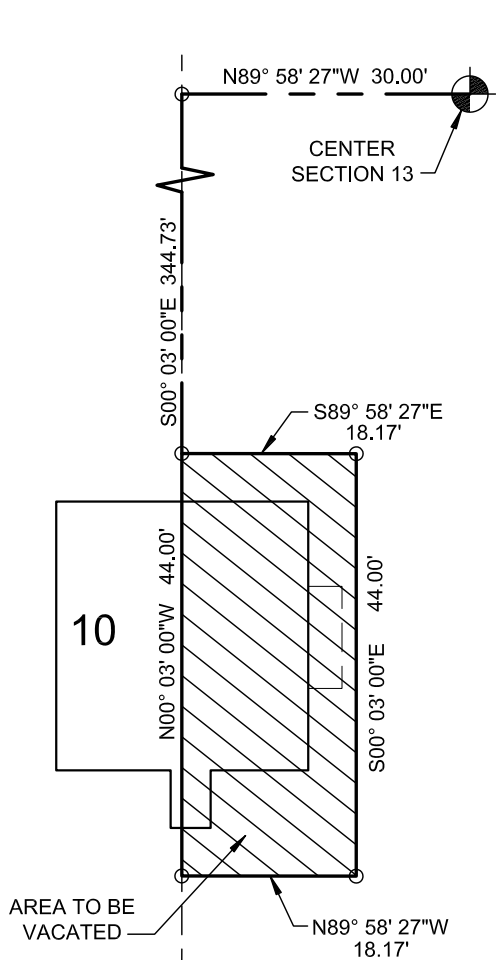

DETAIL 'A'
PORTION 2
SCALE 1"=20'

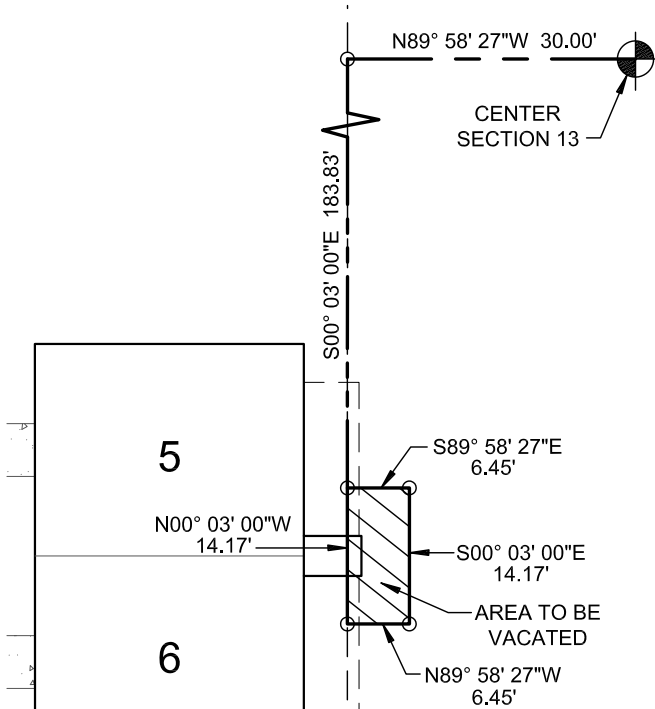

DETAIL 'B'
PORTION 1
SCALE 1"=20'

AN OFFER OF DEDICATION FOR ROAD AND ALL UTILITIES AND INCIDENTAL PURPOSES, RECORDED JULY 13, 1978 AS BOOK 78, PAGE 685 OF OFFICIAL RECORDS.
TO: COUNTY OF SIERRA, A POLITICAL SUBDIVISION
(AFFECTS EASTERLY 30 FEET OF APN 016-040-079-0 AND WESTERLY 30 FEET OF APN 016-040-099-0)

AN EASEMENT FOR ROAD AND UTILITY AND INCIDENTAL PURPOSES IN THE DOCUMENT RECORDED AUGUST 08, 1978 AS BOOK 79, PAGE 193 OF OFFICIAL RECORDS.
(AFFECTS THE EASTERLY 30 FEET)

S89° 58' 27.00"E
510.000

bda **Bisnett Design Associates**

16046 Bear Court
Grass Valley, CA 95949
530.277.9733
bda@bisnettdesign.com

Landscape Architecture & Environmental Planning

MARCH 20, 2019

**OFFER OF DEDICATION
VACATION AREA SKETCH MAP**

EXHIBIT 'A'



NORTH

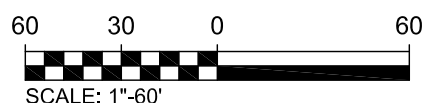

CAUTION: GRAPHIC SCALE MUST BE USED EXCEPT WHERE DIMENSIONED

EXHIBIT B:

Sierra Seniors Offer of Dedication Vacation Legal Description

DESCRIPTION OF PORTIONS OF OFFER OF DEDICATION AREA TO BE VACATED:

Two portions of the Offer of Dedication, recorded July 13, 1976 as BOOK 78, PAGE 685 of Official Records; more particularly described as follows:

Portion 1: Beginning at a point along the western line of said offer of dedication from which the center of Section 13, Township 21, North, Range 15 East, M.D.M. bears North 00 degrees 03 minutes 00 seconds West for a distance of 183.83 feet; THENCE South 89 degrees 58 minutes 27 seconds East for a distance of 30.00 feet; THENCE FROM SAID POINT OF BEGINNING South 89 degrees 58 minutes 27 seconds East for a distance of 6.45 feet; THENCE South 00 degrees 03 minutes 00 seconds East for a distance of 14.17 feet; THENCE North 89 degrees 58 minutes 27 seconds West for a distance of 6.45 feet to a point along the western line of said offer of dedication; THENCE North 00 degrees 03 minutes 00 seconds West for a distance of 14.17 feet along the western line of said offer of dedication to the point of beginning.

Portion 2: Beginning at a point along the western line of said offer of dedication from which the center of Section 13, Township 21, North, Range 15 East, M.D.M. bears North 00 degrees 03 minutes 00 seconds West for a distance of 344.73 feet; THENCE South 89 degrees 58 minutes 27 seconds East for a distance of 30.00 feet; THENCE FROM SAID POINT OF BEGINNING South 89 degrees 58 minutes 27 seconds East for a distance of 18.17 feet; THENCE South 00 degrees 03 minutes 00 seconds East for a distance of 44.00 feet; THENCE North 89 degrees 58 minutes 27 seconds West for a distance of 18.17 feet to a point along the western line of said offer of dedication; THENCE North 00 degrees 03 minutes 00 seconds West for a distance of 44.00 feet along the western line of said offer of dedication to the point of beginning.

**Sierra County
Board of Supervisors'
Agenda Transmittal &
Record of Proceedings**

MEETING DATE: March 21, 2019	TYPE OF AGENDA ITEM: <input checked="" type="checkbox"/> Regular <input type="checkbox"/> Timed <input type="checkbox"/> Consent
--	---

DEPARTMENT: County Counsel APPROVING PARTY: David Prentice PHONE NUMBER: 559-500-1600
--

AGENDA ITEM: Closed session pursuant to Government Code section 54956.9(a) - conference with legal counsel regarding the following litigation: Sierra County v. Loylton Mobile Home Park, Sierra County Superior Court Case No. 7677.

SUPPORTIVE DOCUMENTS ATTACHED: Memo Resolution Agreement Other

BACKGROUND INFORMATION:

FUNDING SOURCE:
GENERAL FUND IMPACT: No General Fund Impact
OTHER FUND:
AMOUNT: \$ N/A

ARE ADDITIONAL PERSONNEL REQUIRED?

 Yes, -- --
 No

IS THIS ITEM ALLOCATED IN THE BUDGET? Yes No

IS A BUDGET TRANSFER REQUIRED? Yes No

SPACE BELOW FOR CLERK'S USE

BOARD ACTION: <input type="checkbox"/> Approved <input type="checkbox"/> Approved as amended <input type="checkbox"/> Adopted <input type="checkbox"/> Adopted as amended <input type="checkbox"/> Denied <input type="checkbox"/> Other <input type="checkbox"/> No Action Taken	<input type="checkbox"/> Set public hearing For: _____ <input type="checkbox"/> Direction to: _____ <input type="checkbox"/> Referred to: _____ <input type="checkbox"/> Continued to: _____ <input type="checkbox"/> Authorization given to: _____	Resolution 2019- _____ Agreement 2019- _____ Ordinance _____ Vote: Ayes: Noes: Abstain: Absent: <input type="checkbox"/> By Consensus
---	---	---

COMMENTS:

CLERK TO THE BOARD

DATE